

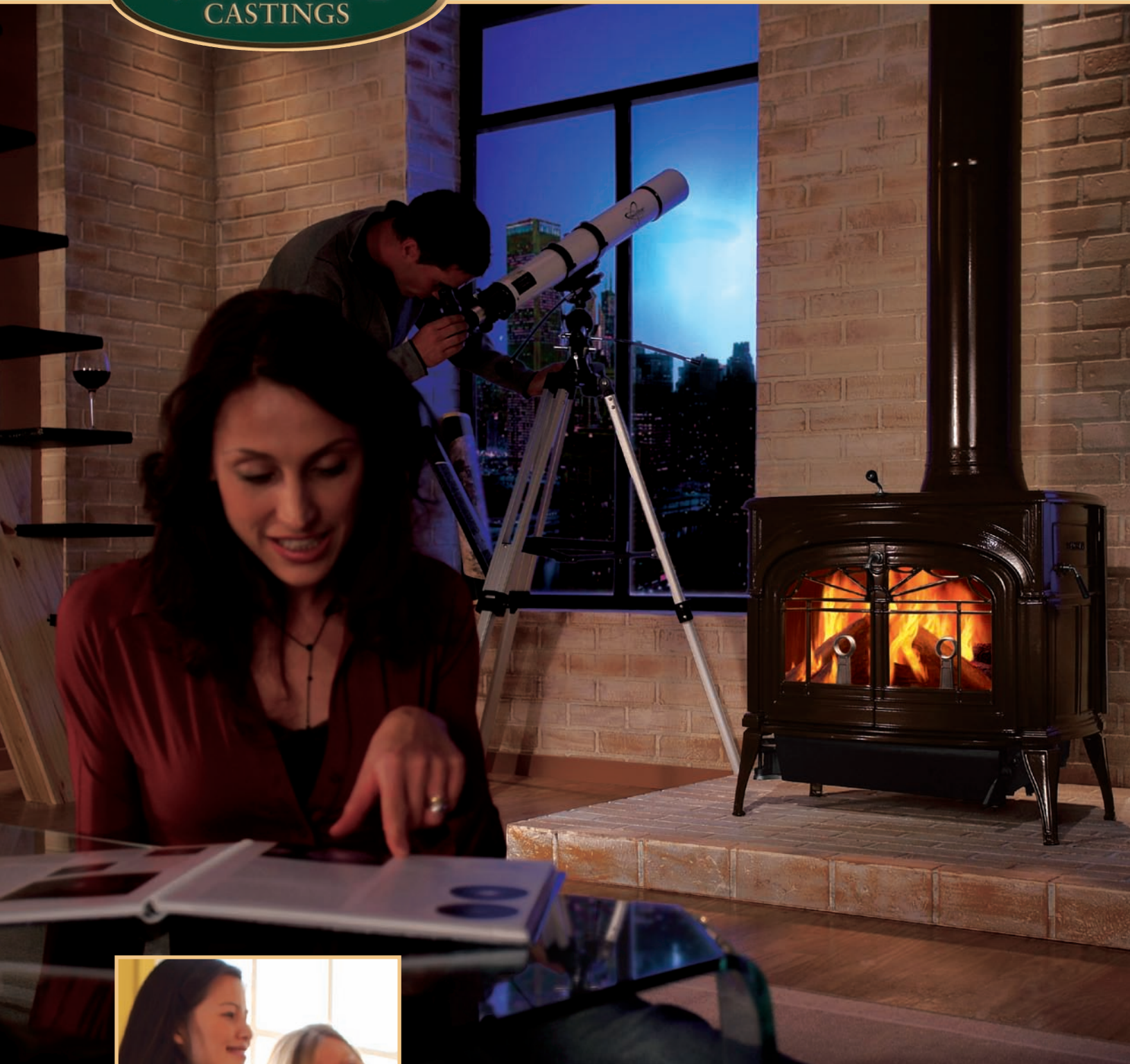

Cast Iron
Catalytic and Non-catalytic Wood Stoves



The beautiful and smart way
to heat your home.

Catalytic Wood Stoves



Where good times and efficient heat meet.

The natural, even warmth of cast iron is enhanced with thermostatically regulated combustion air and the Vermont Castings® signature conveniences of top wood loading and ash handling make these stoves a great choice. Our Catalytic Wood Stoves ensure that more smoke and combustible gasses are converted to useable heat under conditions where other stoves simply cannot.



Defiant Catalytic
in Biscuit

Defiant – Catalytic Standard Features

- Largest Vermont Castings woodburning stove
- Exceptionally large, unobstructed viewing area
- Firebrick protected fire back
- Automatic thermostat control operation
- Innovative swing-out ashpan and cover
- Reversible flue collar
- Clean, convenient top loading
- Bottom heat shield to accommodate standard hearth pad

Optional

- Custom sparkscreen for open door fire viewing (8" chimney only)
- Eight inch oval to six and eight inch round vent adaptors
- Choice of Classic Black or six enamel colors: Bordeaux, Biscuit, Midnight Blue, Chestnut Brown, Ebony Black and Vermont Classic Green
- Matching enamel pipe in six standard colors
- Clearance reducing rear heat shield
- Handy warming shelves with mitten racks



Encore Catalytic
in Bordeaux

Encore – Catalytic Standard Features

- High efficiency – more heat from less wood
- Automatic thermostat for steady heat
- Innovative swing-out ashpan and cover
- Clean, convenient top loading
- Polished cooking griddle
- Low smoke emissions
- Leg levelers for uneven hearth
- Bottom heat shield to accommodate standard hearth pad

Optional

- Custom sparkscreen for open door fire viewing (8" chimney only)
- Choice of Classic Black or six enamel colors: Bordeaux, Biscuit, Midnight Blue, Chestnut Brown, Ebony Black and Vermont Classic Green
- Matching enamel pipe in six standard colors
- Clearance reducing rear heat shield
- Handy warming shelves with mitten racks
- Outside air kit
- 6" flue collar (round)

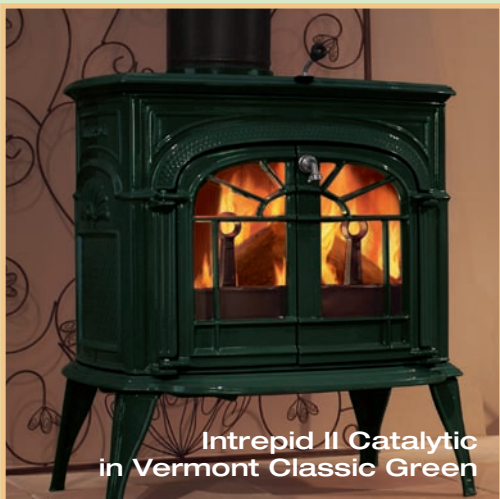

Intrepid II Catalytic
in Vermont Classic Green

Intrepid II – Catalytic Standard Features

- Compact size fits almost anywhere
- Clean-burning EPA rated 2.1 grams/hour
- High efficiency – more heat from less wood
- Automatic thermostat for even heat
- Handy ashpan
- Clean and convenient front and top loading
- Bottom heat shield to accommodate standard hearth pad

Optional

- Custom sparkscreen for open door fire viewing
- Choice of Classic Black or six enamel colors: Bordeaux, Biscuit, Midnight Blue, Chestnut Brown, Ebony Black and Vermont Classic Green
- Matching enamel pipe in six standard colors
- Clearance reducing rear heat shield
- Handy warming shelves with mitten racks
- Height-reducing short legs

Outstanding quality and efficient performance. And built Vermont proud and strong.

The Vermont Castings Stove proudly stands head and shoulders above the rest for enduring strength year after year, and powerful performance you can depend on. From the most clean burning wood stoves on the market, to the latest lustrous colors, Vermont Castings means best of class in all that we do. Warmth. Comfort. And pride. That's what makes every Vermont Castings stove stand above the rest.

Catalytic Wood Stoves

CATALYTIC WOOD STOVES

A higher efficiency heating machine, catalytic wood stoves are ideal for those who wish to supplant a major portion of their heating needs with their wood stove.

- Higher efficiency
- Advanced features such as top-loading, swing-out ashpan and thermostatic control
- Longer burn times



How catalytic combustion works:

- 1) Primary air enters the stove through a thermostatically controlled flap in the back and is preheated as it is drawn through the interior walls of the stove and finally to the air wash.
- 2) Thermostatically controlled secondary air mixes with the smoke (which is unburned wood gases) beginning the secondary combustion process and providing an optional mixture for greater efficiency.
- 3) The mixture passes through a catalytic combustor which lowers the smoke's burning temperature from 1,200 °F to 600 °F and causes it to ignite. This catalytic combustion turns the smoke and other pollutants into usable heat.

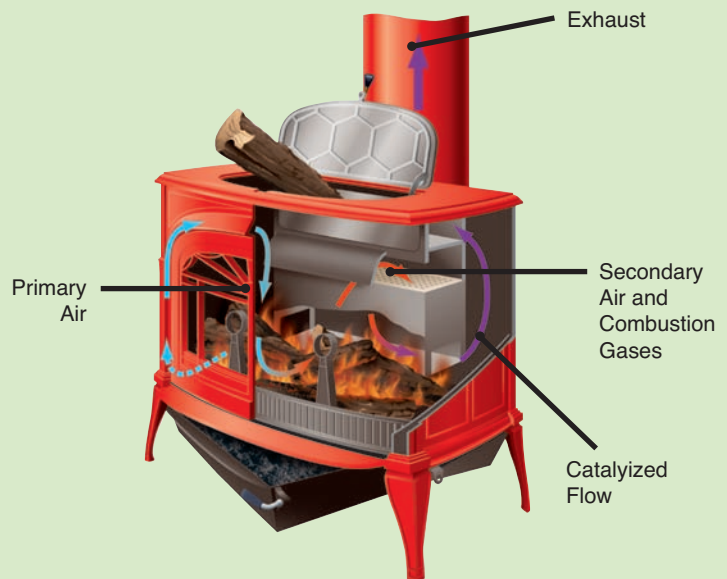

Convenient Features



Wood Made Easy

Easy Ash Handling: Throw away that ash shovel. The unique built-in grate and swing-out ash pan on certain models eliminate all the mess involved with removing ashes from your stove. The ashpan comes with a handled lid for easy removal and disposal. All Vermont Castings wood stoves include a mechanism for safe and easy ash removal.

Top Loading: Forget about bending over to wrestle a log through a stove's front door. Better yet, forget about ashes and sparks falling out the front loading door. Just lift the griddle and let gravity do the work for you. This is the most convenient way to load a stove and is a standard feature on most of our wood stoves.

Non-catalytic Wood Stoves



The remarkably efficient and remarkably beautiful way to heat your home.

We call it the EVERBURN System and it's designed to deliver cleaner emissions and longer burn times, similar to a catalytic system.

Our state-of-the-art design enables Defiant and Encore stoves to burn more steadily and longer on a single load of wood compared to other non-catalytic stoves. So now you can enjoy all of the beauty and style of a traditional cast iron stove with a new level of convenience and efficiency. Just what you'd expect from Vermont Castings.



"Limited Lifetime Warranty"

NON-CATALYTIC WOOD STOVES

The Aspen non-catalytic wood stove feature a conventional non-catalytic combustion system that works like this:

- 1 Primary air enters the stove through an access hole in the back of the stove. The air is preheated as it is drawn through the interior walls of the stove. As this primary combustion air enters the firebox above the glass door, it effectively washes the glass, thus maintaining a cleaner view of the fire.
- 2 To achieve greater efficiency, secondary air enters the firebox bringing about the secondary phase of combustion. Secondary combustion reduces the amount of unburned gasses.



Defiant Non-catalytic
in Classic Black

Defiant - Non-catalytic Standard Features

- Largest Vermont Castings non-catalytic wood-burning stove
- Everburn non-catalytic combustion system
- Convenient top and front loading
- Exceptionally large, unobstructed viewing area
- Firebrick protected combustion chamber
- Innovative swing-out ashpan and cover
- Reversible flue collar
- Fully gasketed construction
- Bottom heat shield
- Leg levelers for uneven hearth

Optional

- Custom sparkscreen for open door fire viewing
- 8" oval to 6" round vent adaptors
- Classic Black or choice of six porcelain enamel colors: Midnight Blue, Bordeaux, Chestnut Brown, Biscuit, Ebony Black and Vermont Classic Green
- Outside air kit
- Matching enamel pipe in six standard colors
- Clearance reducing flue collar heat shield
- Handy warming shelves with mitten racks
- Heat activated fan



Encore Non-catalytic
in Bordeaux

Encore - Non-catalytic Standard Features

- Everburn non-catalytic combustion system delivers the lowest EPA emissions rating in the wood stove industry at 0.7 grams/hour
- Convenient top and front loading
- Clean glass with overfire airwash
- Fully gasketed construction
- Utilizes economical 8" flue with reversible collar
- Convenient swing out ashpan with cover
- Griddle for stovetop cooking
- Durable brick-lined interior
- Bottom heat shield

Optional

- Custom sparkscreen and matching enamel pipe in six standard colors
- Heat activated fan system
- Outside air kits
- Classic Black or choice of six porcelain enamel colors: Midnight Blue, Bordeaux, Chestnut Brown, Biscuit, Ebony Black and Vermont Classic Green
- Mobile home kit (U.S. and Canada)
- 6" cast iron flue collar (round)
- Clearance reducing flue collar heat shield
- Handy warming shelves with mitten racks

Non-catalytic Wood Stoves



Resolute Acclaim
Non-catalytic in Biscuit

Resolute Acclaim – Non-catalytic Standard Features

- High efficiency - more heat from less wood
- Pull-out ashpan
- Clean, convenient top and conventional front loading
- Polished cooking griddle
- Low smoke emissions
- Leg levelers for uneven hearth

Optional

- Custom sparkscreen for open door fire viewing
- Choice of Classic Black or four porcelain enamel colors: Bordeaux, Biscuit, Ebony Black and Vermont Classic Green
- Matching enamel pipe
- Clearance reducing rear and bottom heat shields
- Handy warming shelves with mitten racks
- Outside air kit
- 6" cast iron flue collar



Aspen Non-catalytic
in Bordeaux

Aspen – Non-catalytic Standard Features

- Protective firebrick lining
- Reversible 6" flue collar
- Ash pan (not included in most other small wood burning stoves)
- Thermostatically controlled air supply
- I.R.-Coated Ceramic Glass
- Outside air-ready
- Top Plate Cooking Surface
- Low height for fireplace installations
- Bottom heat shield to accommodate standard hearth pad

Optional

- Clearance reducing rear heat shield
- Classic black or choice of Bordeaux or Vermont Classic Green porcelain enamel finishes
- Outside air kits (U.S. only)



Non-catalytic Wood Stoves

COMBUSTION SYSTEM COMPONENTS

Refractory Fireback (A and B). Highly engineered shapes cast in durable, high temperature refractory make up the rear wall of the stove's firebox. This material survives the superheated environment of the EverBurn system where other materials would not and provides the intricate cast-in detail essential for tuned air flow and fuel load management.

Shoe (C), Formed of the same high temperature refractory, the hollow shoe delivers primary and secondary air to the burning fuel through arrays of tuned air delivery holes. In conjunction with the lower fireback, the shoe forms a turbulent mixing area and entrance to the secondary combustion zone.

Fountain (D), The secondary combustion chamber or "Fountain" is also a highly engineered shape cast in a specialized high temperature and chemical resistant ceramic fiber. The fountain provides a highly insulated extended pathway for unburned combustion products (smoke) leaving the firebox to burn more completely before exiting the stove.



NON-CATALYTIC WOOD STOVES

Homeowners will save money and time with a non-catalytic model. Easier to start and operate, the non-catalytic wood stove is ideal for those with less heating demands on their wood stoves.

- Slightly lower cost
- Easier to operate
- Lively flame picture
- No catalytic combustor to replace

Wood Stove Checklist

- ✓ Ask for a demonstration of top loading and the swing-out ash pan on your dealer's "live model" displays.
- ✓ Look closely at the quality of the cast iron on a Vermont Castings, and compare it to any other cast-iron products on the showroom floor. You will notice that Vermont Castings, surfaces are smoother and the details are more crisp and refined.
- ✓ Look at both catalytic and noncatalytic models; both have advantages.
- ✓ Carefully consider the area to be heated. Choose the size stove that most closely meets those needs.

How it works:

- 1) Primary combustion air enters the stove and is preheated then introduced above the glass doors. This primary air flow is adjustable and provides control of fuel burn rate and heat output. The sweeping action of the airwash system helps keep the glass clean for better fire viewing.
- 2) Jets of combustion air enter through the shoe refractory and maintain a superheated primary combustion zone of coals and burning fuel where combustible gasses ignite as they pass into the secondary combustion zone.
- 3) Flames entering the highly insulated secondary combustion chamber are further mixed with staged secondary combustion air which provides the optimum level of oxygen to more completely burn off any remaining combustible gasses. This results in lower emissions, higher efficiency and a stable, even heat output from your stove.

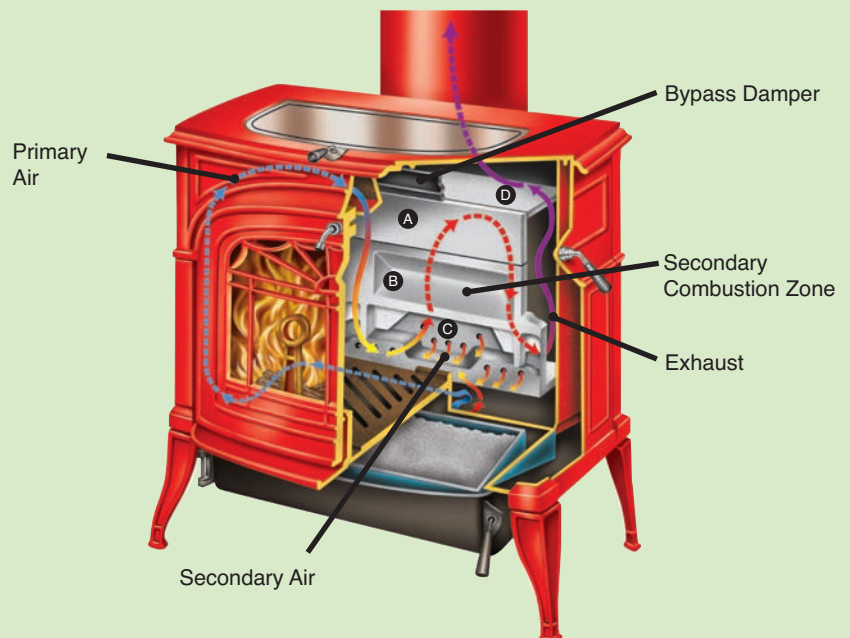

Cast Iron Catalytic Wood Stoves

Models • Defiant • Encore • Intrepid II

DEFIANT

Log Length: up to 24"
 Burn Time: up to 12 hours
 Heating Capacity: up to 2,400 sq. ft.
 Maximum Heat Output: 55,000 BTUs/hr.
 Efficiency Rating: 82.4%
 EPA Emissions Rating: 0.80 grams/hr.
 Weight: 480 lbs.
 Flue Collar: 8" oval, reversible
 (6" Adaptors available**)
 Firebox Size: 3.2 ft.³
 Clearances (with optional stove and pipe heat shields)
 Back: 15" (measured to back of stove)
 Corner: 17"
 See owner's manual

Flue collar in Rear Vent position

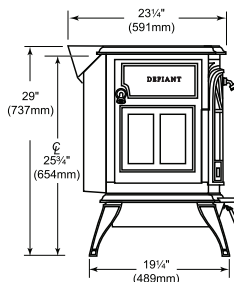

Flue collar in Top Vent position

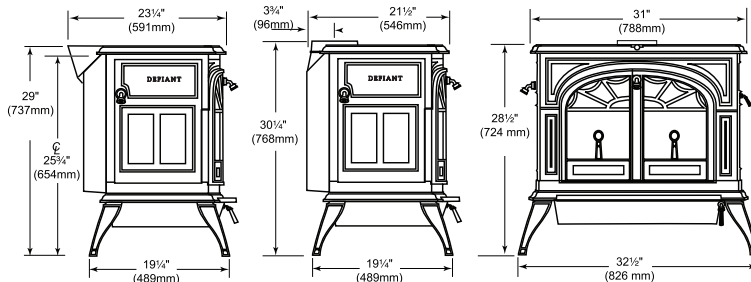

ENCORE

Log Length: up to 20"
 Burn Time: up to 10 hours
 Heating Capacity: up to 1,900 sq. ft.
 Maximum Heat Output: 47,000 BTUs/hr.
 Efficiency Rating: 76.7%
 EPA Emissions Rating: 1.6 grams/hr.
 Weight: 350 lbs.
 Flue Collar: 8" oval, reversible
 (optional round 6" cast iron collar**)
 Firebox Size: 2.3 ft.³
 Clearances (with optional stove and pipe heat shields)
 Back: 15" (measured to back of stove)
 Corner: 17"
 See owner's manual

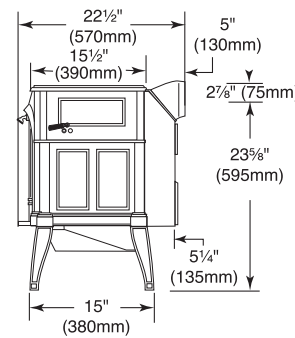
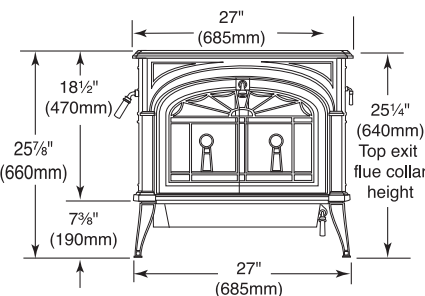

INTREPID II

Log Length: 16"
 Burn Time: up to 6 hours
 Heating Capacity: up to 1,200 sq. ft.
 Maximum Heat Output: 27,000 BTUs/hr.
 Efficiency Rating: 81.1%
 EPA Emissions Rating: 2.1 grams/hr.
 Weight: 223 lbs.
 Flue Collar: 6" round, reversible
 Firebox Size: 1.3 ft.³
 Clearances (with optional shields)
 Back: 12" (measured to back of stove)
 Corner: 12"
 See owner's manual

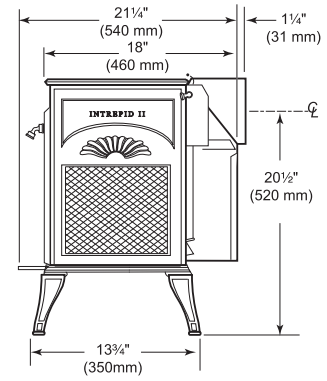
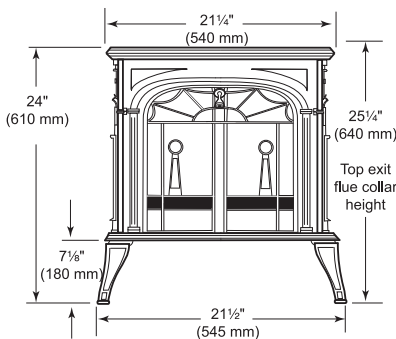

Burn times and heat outputs are based on laboratory testing using full loads of seasoned hardwoods, and may vary depending on how the stove is operated, type of wood and other factors. Average heating capacity is based on operation in building code-conforming homes under typical winter climate in New England, and also may vary. *Efficiency ratings are based on independent laboratory testing. **6" chimney permits closed door burning only. See owner's manual for complete installation and clearance requirements.

All Vermont Castings stoves meet Washington State emissions standards.

Strength Heart of your home
 Performance

Cast Iron Non-catalytic Wood Stoves

Models • Defiant • Resolute Acclaim • Encore • Aspen



DEFIANT

Log Length: up to 24"
 Burn Time: up to 14 hours
 Heating Capacity:* up to 2,400 sq. ft.
 Maximum Heat Output: 60,000 BTUs/hr.
 Efficiency Rating: 69%
 EPA Emissions Rating: .75 grams/hr.
 Firebox Volume: 3.1 cubic feet
 Weight: 510 lbs.
 Flue Collar: 8" oval, reversible
 6" Adaptors available

**Second Cleanest
 Burning EPA Certified
 Wood Stove**

Clearances (with optional collar and pipe heat shields and 8" chimney)
 Back: 11 1/4" (measured to back of stove)
 Corner: 25"
 See owner's manual

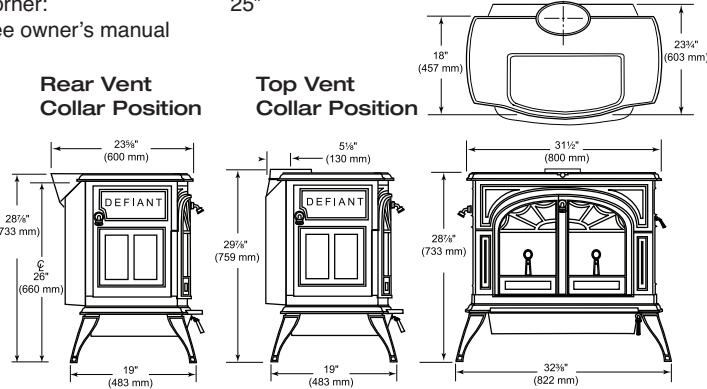

RESOLUTE ACCLAIM

Log Length: 16"
 Burn Time: up to 9 hours
 Heating Capacity:* up to 1,600 sq. ft.
 Maximum Heat Output: 40,000 BTUs/hr.
 Efficiency Rating: 72.1%
 EPA Emissions Rating: 3.4 grams/hr.
 Firebox Volume: 1.7 cubic feet
 Weight: 425 lbs.
 Flue Collar: 6" round, reversible
 Clearances (with optional stove and pipe heat shields)
 Back: 14" (measured to back of stove)
 Corner: 15"
 See owner's manual

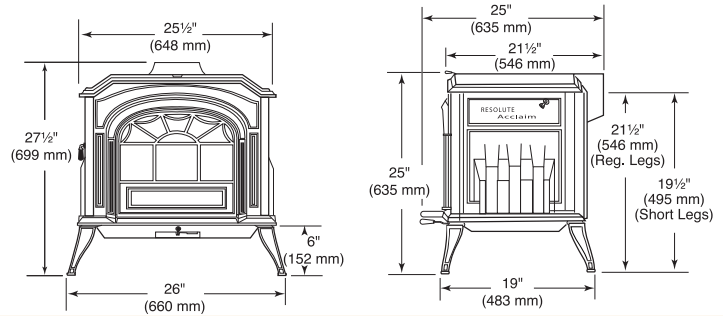

ENCORE

Log Length: up to 20"
 Burn Time: up to 10 hours
 Heating Capacity:* up to 1,900 sq. ft.
 Maximum Heat Output: 50,000 BTUs/hr.
 Efficiency Rating: 68%
 EPA Emissions Rating: 0.7 grams/hr.
 Firebox Volume: 2.1 cubic feet
 Weight: 395 lbs.
 Flue Collar: 8" oval, reversible
 Optional 6" collar (round)

**Cleanest Burning
 EPA Certified
 Wood Stove**

Clearances (with optional collar and pipe heat shields)
 Back: 9 3/4" (measured to back of stove)
 Corner: 19"
 See owner's manual

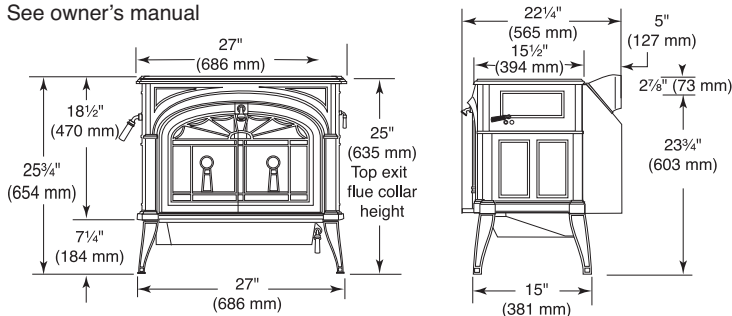

ASPEN

Log Length: 16"
 Burn Time: up to 5 hours
 Heating Capacity:* up to 600 sq. ft.
 Maximum Heat Output: 18,000 BTUs/hr.
 Efficiency Rating: 69.5%
 EPA Emissions Rating: 4.3 grams/hr.
 Weight: 240 lbs.
 Flue Collar: 6" round, reversible
 Clearances (with optional stove and pipe heat shields)
 Back: 9"
 Corner: 13"
 See owner's manual

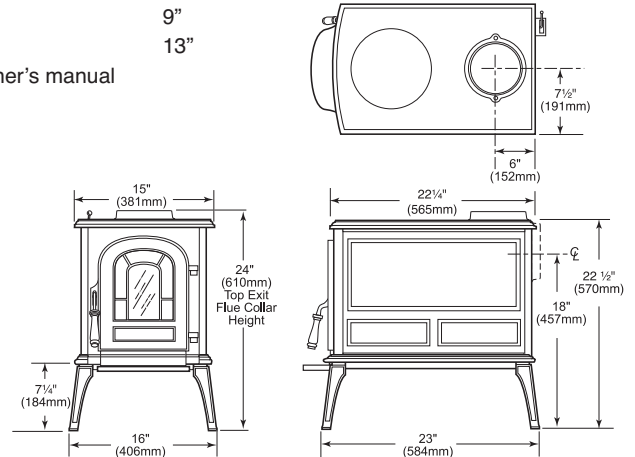

* Actual heating capacity will vary based on home construction, fuel and climate. Clearances shown are for quick reference only. See owner's manual for complete clearance and installation requirements specifications available on the website.



ph: 1.800.525.1898
 www.vermontcastings.com
 www.majesticproducts.com

YOUR DEALER